

AN ARCHITECT'S GUIDE TO THE DURO-LAST ROOFING SYSTEM

# DURO-LAST<sup>®</sup>

## ROOFING, INC.



SPECIFY THE PROVEN PERFORMER<sup>®</sup>:  
THE DURO-LAST ROOFING SYSTEM



# IF YOU CAN DRAW



*Your designs*

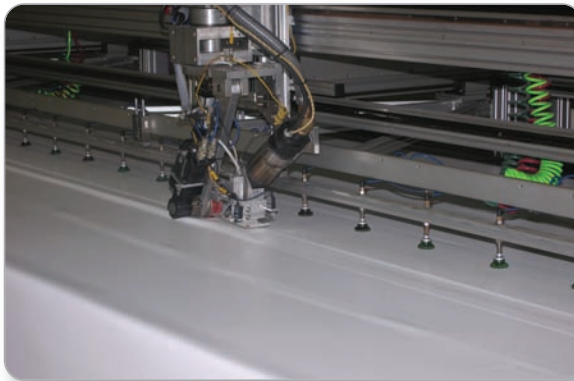

*Precision-fabricated by Duro-Last*



*Complete roofing system*

Dealing with building designs and roofing details can be a daily challenge for you. No matter how simple or complex your project might be, at Duro-Last® Roofing, Inc., our philosophy is: *if you can draw it, we can make it*. Our approach is unique in the commercial roofing industry because the entire system that you design – from deck sheets and parapet walls to penetrations and edge details – is prefabricated in our controlled factory environment, rather than manufactured on the rooftop.

If your project requires a unique configuration, additional fastening strength, or a special wind, fire or hail assembly, Duro-Last's experienced team of engineers can help you design it. Then we'll make the roofing system in our factory to your specifications, ready to be installed at the job site.

Duro-Last's precision fabrication expertise means that you and your clients are assured superior watertight protection for years to come.

Duro-Last offers the best design support in the roofing industry. Whether you need CAD drawings for a meeting, specifications for a unique project, or an answer to a technical question, we provide the resources you need to get the job done.

Over a billion square feet of Duro-Last membrane have been installed since 1978. Our reputation for quality stems from long-term, steady company ownership, a time-tested product formulation, and a highly-refined installation method that relies on reputable, factory-authorized contractors.

For your next roofing project, draw on the quality, reliability, and durability delivered by "The World's Best Roof"® – the precision-fabricated Duro-Last roofing system.

# IT, WE CAN MAKE IT.

## Prefabrication...The Duro-Last Difference

Roof leaks usually stem from installation errors – not surprising, considering how challenging a rooftop environment can be and the amount of hands-on labor a typical roof installation requires.

Duro-Last addresses this issue by prefabricating every roofing system in a controlled factory environment. By manufacturing each roof to specification, using state-of-the-art technology, Duro-Last reduces the amount of field welding that contractors must perform on the rooftop by 80-85%. This significantly reduces the likelihood of leaks developing in the future.

Duro-Last's edge-to-edge precision fabrication provides peace of mind, ensuring a predictable installation that delivers long-term, worry-free, leak-proof protection.

## Less Seaming Means An Easier, More Reliable Installation

The diagrams shown at the right compare the seaming required on a typical 42,000 square-foot roof using EPDM roll goods and the prefabricated Duro-Last roofing system. The red lines on both diagrams indicate the amount of on-site rooftop seaming required. The blue lines on the Duro-Last diagram show the seams that are completed in the Duro-Last factory.\* By eliminating most on-site rooftop seaming, we substantially reduce the potential for leaks and add the advantages of faster, quieter installations, less maintenance, and reliable roof performance.

\* The Duro-Last roofing system has similar seaming advantages over other rolled systems that must be constructed on the rooftop, including modified cap sheet and TPO.

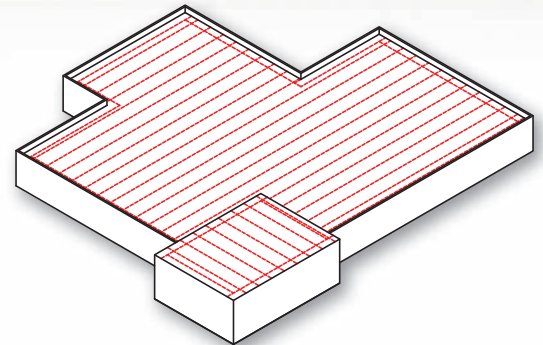

**EPDM (Rubber) Sheets - 120" Roll Width**  
**Lineal Feet of Field Seams - 5,130**

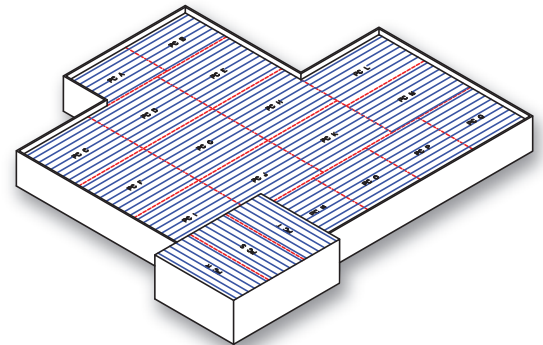

**Duro-Last Roofing System**  
**Prefabricated Membrane Sheets**  
**Lineal Feet of Field Seams - 1,278**



# EXCEPTIONAL ROOFS REQUIRE

With the Duro-Last roofing system, you design the roof, and we build it. Deck sheets are custom-prefabricated in sections of up to 2,500 square feet each. Plus, we produce virtually all other components in our controlled factory environment. The illustrations and photographs on these pages represent only a small portion of the functional and aesthetic accessories that we offer. Custom prefabricated stack and curb flashings eliminate nearly all rooftop labor from the most critical roof areas – penetrations and transitions. Our EXCEPTIONAL® Metals subsidiary makes a wide variety of standard and custom metal details, providing the integrity and appearance your clients expect.



**A** FASCIA COVER

**B** 2-PIECE SNAP-ON COMPRESSION

**C** SNAP-ON FASCIA/BASE

**D** SNAP COPING

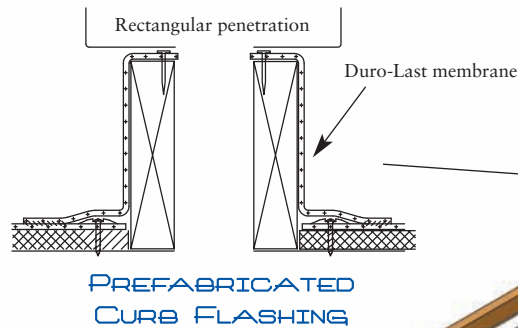

PREFABRICATED CURB FLASHING

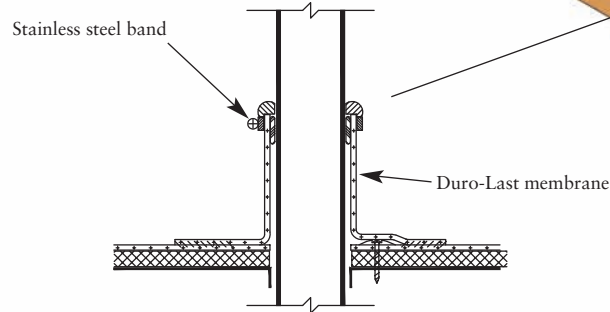

PREFABRICATED STACK FLASHING

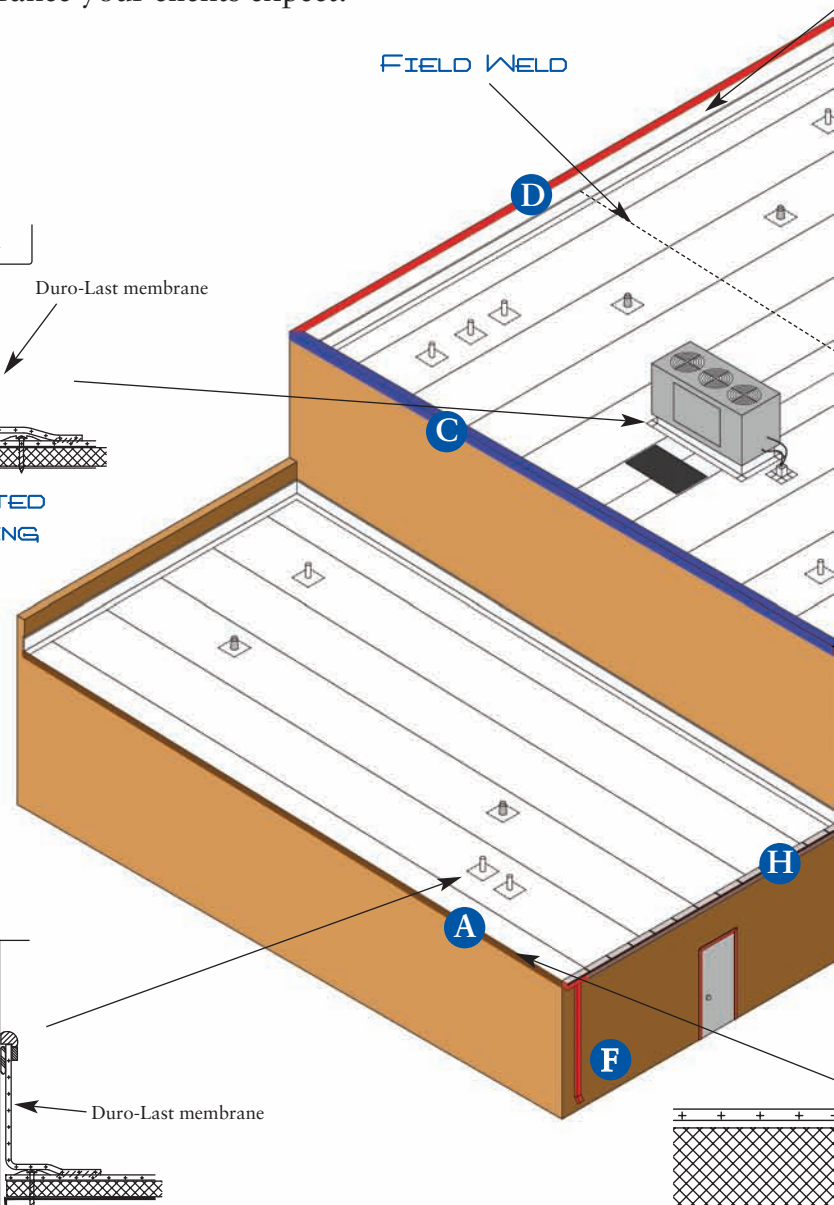

PREFABRICATED VINYL EDGE DETAIL

(Fascia shown. Vinyl gravel stone drip edge also available.)

*Note: Illustrations are not to scale.*

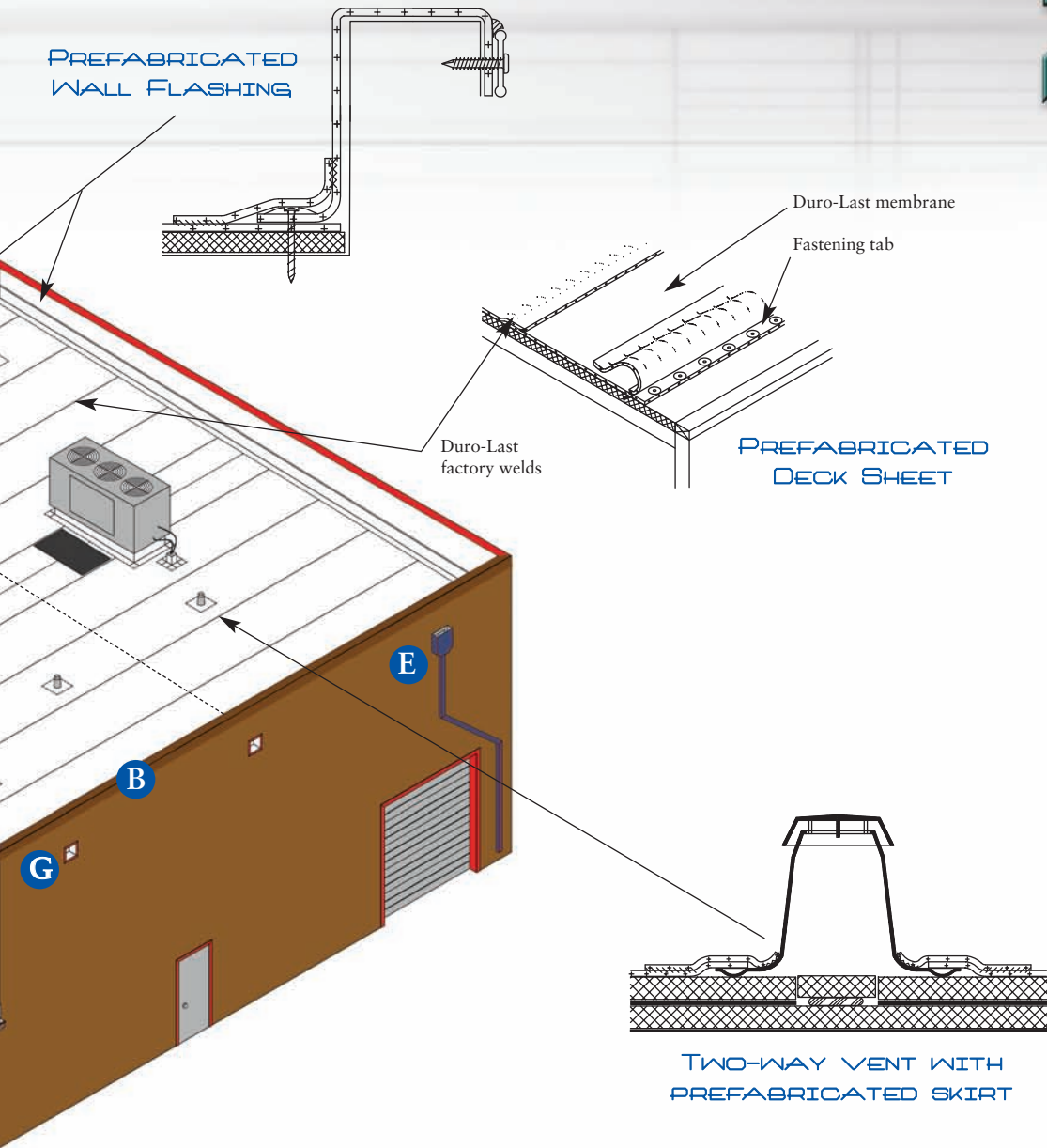

**E** COLLECTOR BOX



**F** BOX GUTTER ASSEMBLY



**G** SCUPPER



**H** D-STYLE GUTTER SYSTEM

DURO-LAST AND EXCEPTIONAL METALS OFFER A SINGLE SOURCE OF PREFABRICATED ROOFING MATERIALS MANUFACTURED FOR UNSURPASSED PROTECTION, DURABILITY, AND EFFICIENCY.

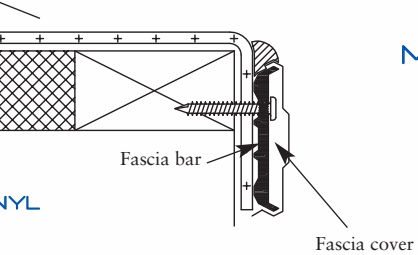

NYL  
p and

# PHYSICAL PROPERTIES

You depend on a roofing system that can offer the physical performance properties that your clients demand. The Duro-Last roofing system has successfully passed the following tests for single-ply roofing systems.

Tests outlined by ASTM D-4434	Test Description	Test Method	Metric Results	U.S. Standard Results
	Thickness-Nominal	ASTM D 751	1 mm.	40 mil - Type IV (50 and 60 mil also available)
	Breaking Strength	ASTM D 751 - Grab Method	1912 x 1636 N	435 x 368 lbf./in.
	Elongation at Break	ASTM D 751 - Grab Method		30%
	Heat Aging	ASTM 3045, 56 days @ 176°F		Pass
	Factory Seam Strength	ASTM D 751 - Grab Method	2081 N	468 lbf.
	Tearing Strength	ASTM D 751 - Procedure B	404 x 569 N	91 x 128 lbf.
	Low Temperature Bend	ASTM D 2136@-40°F		Pass
	Accelerated Weathering	ASTM G 154 (Formerly G53)	No cracking, checking, crazing or erosion at 5,000 hours of exposure. Pass	
	Linear Dimensional Change	ASTM D 1204 - 6 hrs. @ 176°F		-0.2%
	Water Absorption	ASTM D 570 - 166 hrs. @ 158°F		1.40%
	Static Puncture	ASTM D 5602	25 kg.	56 lb.
	Dynamic Puncture	ASTM D 5635	20 J	474 pdl-ft.

Additional Tests	Test Description	Test Method	Metric Results	U.S. Standard Results
	Fungi Resistance	ASTM G-21	No sustained growth or discoloration	
	Solar Reflectance	ASTM C1549	88%	
	Thermal Emittance	ASTM C1371-98	87%	
	Thermal Emissivity	ASTM E408	95%	
	EMMAQUA Exposure	ASTM G90, Desert Sun	339,790 M/J/m <sup>2</sup>	>8.1 million Langley's
	Moisture Vapor Transmission	ASTM E-96, Proc. B, Method A	<.086 g/hr/m <sup>2</sup>	<.25 U.S. Perms
	Weight	ASTM D 751	1.1 kg per m <sup>2</sup>	.22 lb. per ft <sup>2</sup>
	Underwriters Laboratories	UL-790	Classes A, B & C approved	
	Factory Mutual Research	ASTM E-108; FM 4450 & FM 4470	Rated 1-60, 1-90, 1-105, 1-135, 1-150, 1-165, 1-210, and 1-270	

The Duro-Last membrane is available in white, tan, and gray.

## MATERIALS THAT CAN BE USED SAFELY WITH THE DURO-LAST ROOFING SYSTEM

The Duro-Last roofing membrane is extremely durable and compatible with dozens of chemicals, construction products, and other materials. Some of the most common are below. For information about materials not listed, contact the Duro-Last Engineering Services Department at 800-248-0280.

- Acid Rain
- Brick & Masonry Cleaner
- Ethyl/Methyl Alcohol
- Linseed Oil
- Sea Water
- Acrylic/Latex Paint
- Cooking Grease
- Furnace Residue
- Nitrogen Sulfate
- Soldering Acid/Flux
- Bird Droppings
- Detergent Solution
- Hydrofluoric Acid Cleaner
- Polyethylene
- Tannic Acid
- Bleach
- Diatomaceous Earth
- Incinerator Ash
- Polypropylene
- Triethylene Glycol

# CONTINUING EDUCATION CREDITS

AS A REGISTERED PROVIDER OF AIA/CES COURSES\*, DURO-LAST OFFERS THE FOLLOWING:

## One-Hour Roofing Fabrication Facility Tour – STD001

A guided tour of a roofing system fabricating facility. 1 Credit

## Two-Hour Roofing Fabrication Facility Tour – STD002

A guided tour of a roofing system fabricating facility. Includes classroom session and demonstration. 2 Credits

## Three-Hour Facility Tour – STD003

Guided tour of roofing system manufacturing complex, including knitting, calendering, lamination, roofing system fabrication laboratory, and classroom demonstration. 3 Credits

## Thermoplastic Roofing – Materials and Systems – STD004

Overview of single-ply installation methods, seaming and inspection, and a review of insulation types. 1 Credit

## Installation, Seaming, And Inspection of Single-Ply Roofing – STD005

Overview of single-ply installation methods, seaming and inspection, and a review of insulation types. 2 Credits

## Energy Studies, Codes, And The Sustainable Roof – STD006

Summary of recent studies and research on reflective roofing and environmental impacts. Discusses sustainable design and life-cycle issues. 1 Credit

## Rooftop Job-Site Tour – STD007

Guided tour of a Duro-Last roofing system installation in progress. 1 Credit

## Cool Thermoplastic Roofing Systems For Sustainable Buildings – STD008

Thermoplastic roofing as a component of high-performance buildings. Review of infrared case studies for cool roofs and energy savings. 1 Credit

## PVC Single-Plies As Sustainable Roofing Systems – STD009

Review of current issues regarding PVC-based roofing and summary of characteristics of thermoplastic single-plies compared to alternative systems. 1 Credit

## Beyond Cool And Sustainable – The Five E's Of High-Performance Roofing – STD010

Identification and discussion of the “Five E’s” of high-performance roofing and a review of the checklist of high-performance attributes. 1 Credit



Education and  
teamwork build  
successful  
relationships.



\*All courses qualify for Health, Safety, and Welfare (HSW) credits.

# DURO-LAST: THE PROVEN PERFORMER®



You depend on a roofing system that has the code approvals your clients require. The Duro-Last roofing system has met or exceeded all major fire/wind code requirements, and obtained necessary regional approvals throughout the United States and Canada.

Duro-Last participates in all major technical committees in the roofing industry, plus the American Society of Testing Materials (ASTM); American Institute of Architects (AIA); Construction Specification Institute (CSI); Roof Consultants Institute (RCI); National Roofing Contractors Association (NRCA); and the Single Ply Roofing Industry (SPRI).

Duro-Last is a charter partner of the ENERGY STAR® Roof Products Program; a charter member of the Cool Roof Rating Council (CRRC); and a member of the United States Green Building Council (USGBC). Duro-Last is also a member of the Vinyl Roofing Division of the Chemical Fabrics and Film Association (CFFA).



“The World’s Best Roof”® is backed by the roofing industry’s best warranty.

Duro-Last is so confident in the durability of our roofing systems that we protect commercial and industrial installations with the best warranties in the industry. Our standard, comprehensive 15-year full warranty is transferable, has no exclusions for ponding water, and provides coverage against consequential damages that result from defects in the Duro-Last material and/or installation workmanship. Duro-Last also has 20-year warranties available.

Draw on the experience of Duro-Last. With almost 30 years of delivering leak-proof protection for buildings of all types across North America, the precision-fabricated Duro-Last roofing system is the right choice for your next roofing project.



525 Morley Dr.  
Saginaw, MI 48601  
**800-248-0280**  
Fax: 800-432-9331

111 N. Valley Dr.  
Grants Pass, OR 97526  
**800-356-6646**  
Fax: 800-566-2698

## DURO-LAST MANUFACTURING FACILITIES

Architect Booklet 5/07 – 95655-010 / M#DL09-0010

1409 E. SADC Ave.  
Sigourney, IA 52591  
**888-500-3574**  
Fax: 888-501-3574

6200 I-55 South  
Jackson, MS 39272  
**800-434-3876**  
Fax: 866-602-4387